

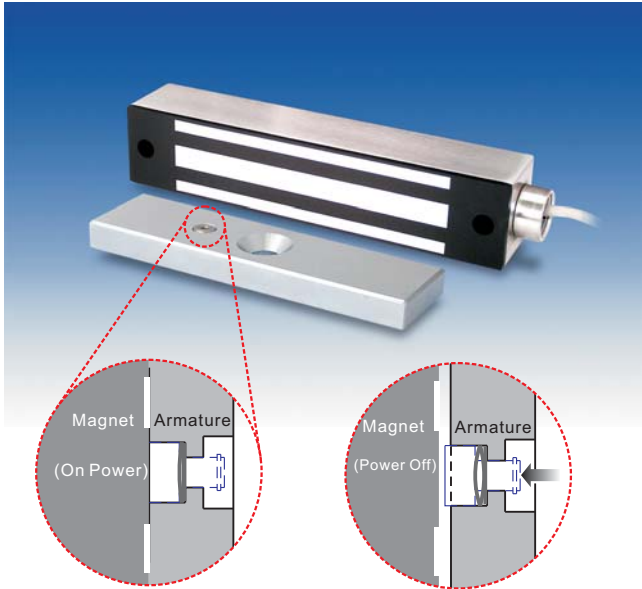

Fire Exposure and Hose Stream Tests were conducted in accordance with the standard, "Positive Pressure Fire Tests of Door Assemblies," ANSI / UL 10B and 10C, uniform building code standard UBC 7-2 (1997).



#### Unique Anti-Residual design

When there is no power, there will be no holding force, and the push-off button will pop out immediately, to release the Electromagnetic Lock and the Armature Plate for no residual magnetism.

#### Statement

The Electromagnetic Locks are totally sealed in an epoxy filled stainless steel case for water-resistant and vandal-resistant purpose. A threaded conduit fitting ensures weather resistant protection of the wiring therefore it is ideal for indoor and outdoor applications, even in severe weather.

We offers up to 600 pounds holding force with 12V DC power input (24V DC or 12/24V DC dual input voltage available by special order), and with the Z-GL600 bracket (optional) can be installed on in-swinging door. It is the best choice for electronic security industry and system integrators.

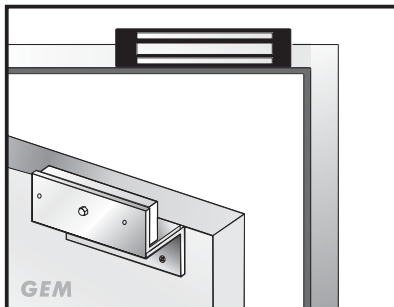

#### Specifications

- Voltage Tolerance: 15%
- Current Draw: 508mA@12Vdc (at temperature 20C)
- Operating Temperature: -10~55C (-14~131F)
- Humidity: 0~95% non-condensing.
- Lock's surface Temperature (when the power is on): <current temperature +20C
- Holding Force: Up to 600 lbs (272 Kg)
- Dimensions:
  - Magnet: (L) 203, (W) 43, (D) 40 mm
  - Armature Plate: (L) 159, (W) 41, (D) 14 mm
- Special Finishes for magnet and armature plate: Zinc
- Epoxy Potting Compound: E87252 (S), UL94V-0
- Weight (Approx. ): 2.0 Kg
- Magnetic bond sensor monitor output (GL600R-F) (SPDT rated 0.25A@12V DC), remotely monitors the door lock or unlock status. (N.C. Output--Door opened; N.O. Output--Door closed)

#### Optional Brackets

With Z-bracket for in-swinging doors

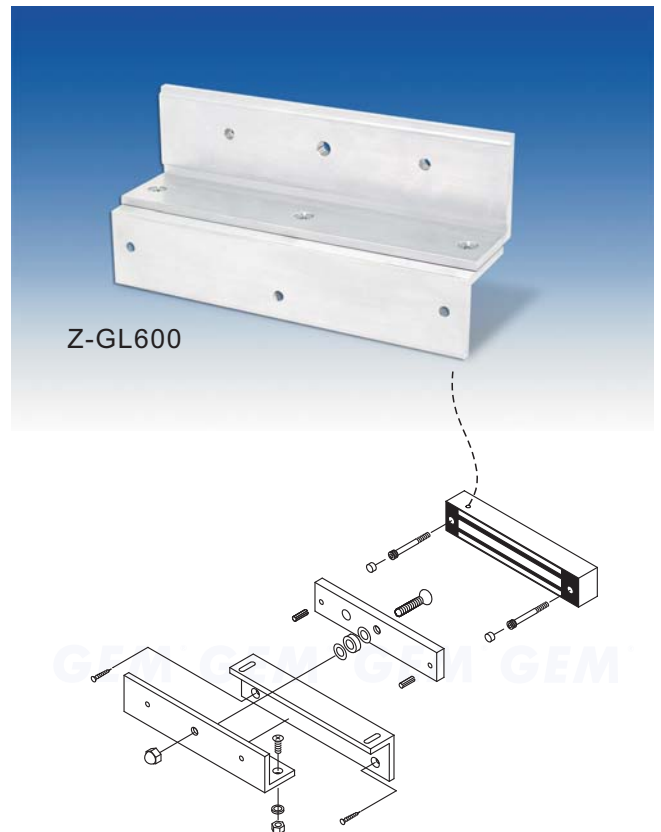

#### Warranty

The product is warranted against defects in material and workmanship while used in normal service for a period of 5 year from the date of sale to the original customer. The GEM policy is one of continual development and improvement; therefore GEM reserves the right to change specifications without notice.

#### GIANNI INDUSTRIES, INC.

No. 13, Zhong Sing Road, Tu-Cheng Industrial Zone,  
 Tu-Cheng City, Taipei, Taiwan 23678  
 Tel: 886-2 2267 7986 / Fax: 886-2 2267 9876  
 E-Mail: info@gianni.com.tw  
 Website: gianni.tw  
 Copyright 2008 Gianni industries, inc. All rights reserved.  
 DM-CA-GL600-F Ver. C Published on 2008.05.12



The products are manufactured under an ISO 9001 & QC 080000 Certified Quality Management Program environment back its product quality, performance and commitment to customer satisfaction.